

PA02 DESIGN IDEAS

BACKGROUND

In 1985, Apex first addressed inquiries on how the PA02 could be used to second source the LH0101. Now, because of Apex's commitment to continue production of the PA02, it is the part of choice for most new designs. For retrofit situations, the PA02 can be substituted for the LH0101 without requiring a PC layout change.

COMPARING THE LH0101 AND THE PA02

The PA02 can satisfy the majority of applications now using the 0101, and can often do it with improved frequency response, linearity and distortion. The table below and the notes that follow compare the two devices.

KEY SPECIFICATION COMPARISON

	LH0101 K	LH0101 AK	LH0101 CK	LH0101 ACK	PA02	PA02A	PA02M	Units
V _{OS} , Initial	10	3	10	3	10	3	10	mV
V _{OS} , vs. Temp	15	7	15	7	13	5.5	15	mV
Bias Current, Initial	1000	300	1000	300	200	100	200	pA
Offset Current, Initial	250	75	250	75	100	50	100	pA
Temp Range	-55/+125	-55/+125	-25/+85	-25/+85	-25/+85	-55/+125	-55/+125	°C
Power Bandwidth	300	300	300	300	350	350	350	kHz
Slew Rate (minimum)	N/A	7.5	N/A	7.5	13	13	13	V/μs
Distortion @ 0.5w, 1 kHz, 10 ohms (typical)	0.008	0.008	0.008	0.008	0.004	0.004	0.004	%

Note: The LH0101 is rated from ±5V to ±22V. The PA02 is rated from ±7V to ±19V. Do not use the PA02 below ±7V (14V total) or above ±19V (38V total).

PIN-OUT COMPARISON

LH0101 Function	Pin No.	PA02 Function
SC+	1	RCL+
V+	2	+V _S
Feedback (Note 1)	3	Out
-IN	4	Out
+IN	5	-IN
V-	6	+IN
SC-	7	-V _S
Out	8	RCL-
	Case	Isolated



NOTE 1: MAY BE "OUT" OR "N/C", DEPENDING ON DATA SHEET REVISION

The PA02 can often drop into the LH0101 socket and improve performance in the areas noted above. This "drop in" status applies when the LH0101 does not employ the swing enhancement network. More simply stated, where Pin No. 3 is tied directly to the output (i.e., the case), the 0101 and PA02 are often interchangeable. For circuits which do employ the swing enhancement, one resistor should be removed and another replaced with a jumper. This retrofit saves parts and assembly cost and improves circuit efficiency by eliminating the drop across each of the two resistors. In both cases, the case of the PA02 is tied to the output. This is acceptable.

“DROP IN” EXAMPLE

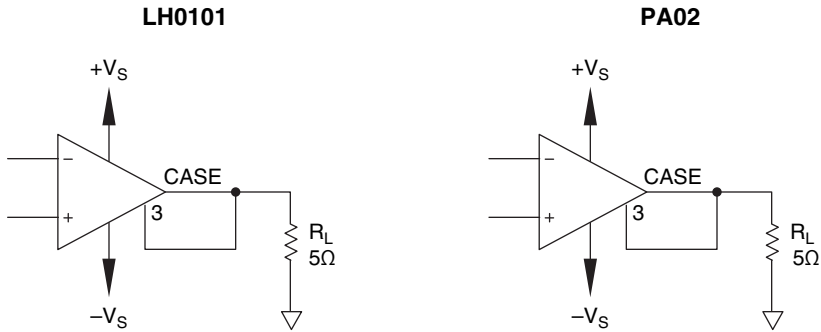

MODIFICATION EXAMPLE

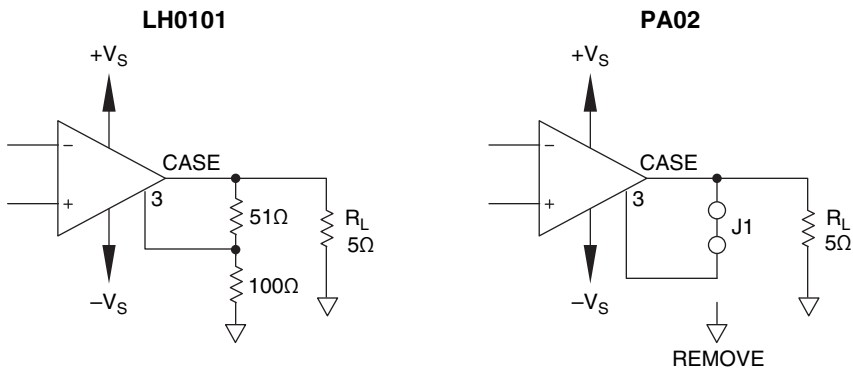

QUESTIONS?

If you have questions, or would like further assistance converting your design to the PA02, please call the Apex Applications Hotline at 1-800-546-2739.